

FRIGID-X™ ADJUSTABLE SPOT COOLER

Produce cold air as low as minus 30° F (minus 34° C) from compressed air to spot cool with easy adjustability

WHAT ARE THEY - REASONS TO USE

The Frigid-X™ Adjustable Spot Cooler is a low cost and maintenance free system which utilizes a vortex tube to produce cold air at one end.

The Frigid-X™ Adjustable Spot Cooler temperature can be adjusted using a knob at the hot end to set the temperature precisely to your requirements. Temperatures range from approximately minus 30°F to room temperature and can be easily set with a thermometer.

The Frigid-X™ Adjustable Spot Cooler System comes with three brass generators for flow rate adjustment - 15 SCFM (425 SLPM), 25 SCFM (708 SLPM) and 30 SCFM (850 SLPM) providing refrigeration up to 2100 BTU/hr (615 Watts).

Cold air is directed using the flexible tubing. A magnetic base is standard for portability and easy mounting of the adjustable spot cooler.

Units are available with either a single point hose kit for small surface area or a dual point hose kit when heat is generated over a larger surface area. Adjustable spot cooler produces a wide range of airflow and temperature by adjusting the knob at the hot end and changing the various generators supplied.

The generators control the air consumption and are easily interchangeable. Adjustable spot cooler has a 25 SCFM (708 SLPM) generator installed that will produce up to 1,800 Btu/hr. of cooling. If less is required, the 15 SCFM (425 SLPM) generator can deliver 1,100 BTU/Hr. If more cooling is needed Nex Flow™ can supply you with the 30 SCFM (850 SLPM) generator for up to 2,100 BTU/Hr. of cooling.

WHY THE FRIGID-X™ ADJUSTABLE SPOT COOLER OVER OTHERS:

All Metal Parts, Stainless Steel Body, Quiet - Tests Show Frigid-X™ Adjustable Spot Cooler is consistently more quiet than the competition.



FRIGID-X™ ADJUSTABLE SPOT COOLER ADVANTAGES :

- ▶ No moving parts.
- ▶ Quiet
- ▶ Driven by air not electricity.
- ▶ Small and lightweight - portable.
- ▶ Low in cost compared to most others
- ▶ Superior design and performance
- ▶ Maintenance free operation
- ▶ Made of durable stainless steel and metal parts, no cheap plastic parts
- ▶ Adjustable temperature range
- ▶ Generators are interchangeable
- ▶ System uses strong magnetic base

A Model 57025AS is used to cool a milling operation of a special ceramic material where the temperature had to be tightly controlled.

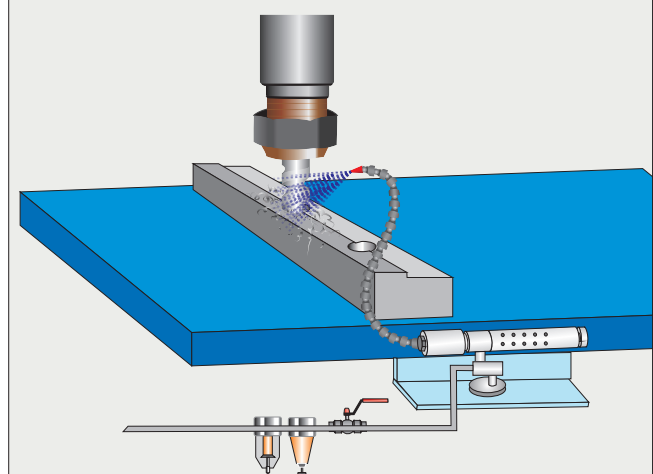

FRIGID-X™ ADJUSTABLE SPOT COOLER – HOW IT WORKS

Frigid-X™ - Adjustable Spot Cooler - Compressed air enters at point (A) into the vortex tube component of the spot cooler. The vortex tube splits the compressed air into a hot (B) and cold (C) stream of air. The hot air from the vortex tube is vented to the atmosphere at point (D) after being muffled to reduce noise. Cold air enters into the muffler (E) and then distributed through the hose distribution kit (F) and onto the item being cooled. A strong magnet (G) holds the spot cooler in place. The temperature of the cold air is controlled by an adjustable knob.

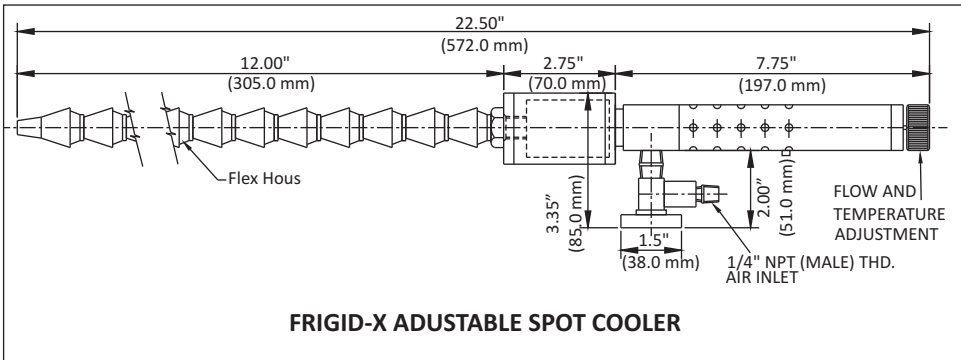
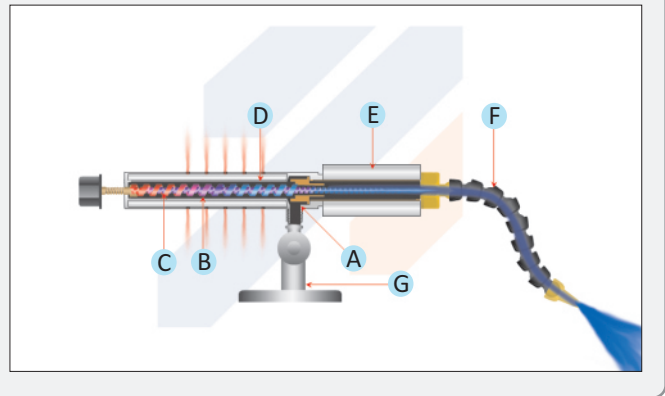

FRIGID-X ADJUSTABLE SPOT COOLER

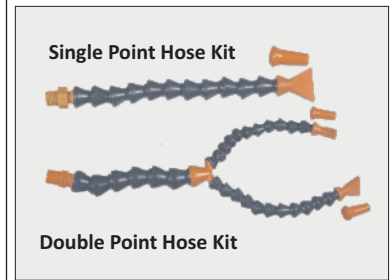

FRIGID-X™ ADJUSTABLE SPOT COOLER APPLICATIONS:

- ▶ Solder Cooling
- ▶ Adjusting thermostats
- ▶ Cool plastic machined parts
- ▶ Set hot melt adhesives
- ▶ Cool welding horns on ultrasonic
- ▶ Cool molded plastics
- ▶ Cool Electronic components
- ▶ Cool heat shrink tubing

INLET PRESSURE PSIG (Bar)	AIR CONSUMPTION SCFM (SLPM)	SOUND LEVEL dBA
100 (6.9)	15 (425)	70
100 (6.9)	25 (708)	71
100 (6.9)	30 (850)	72

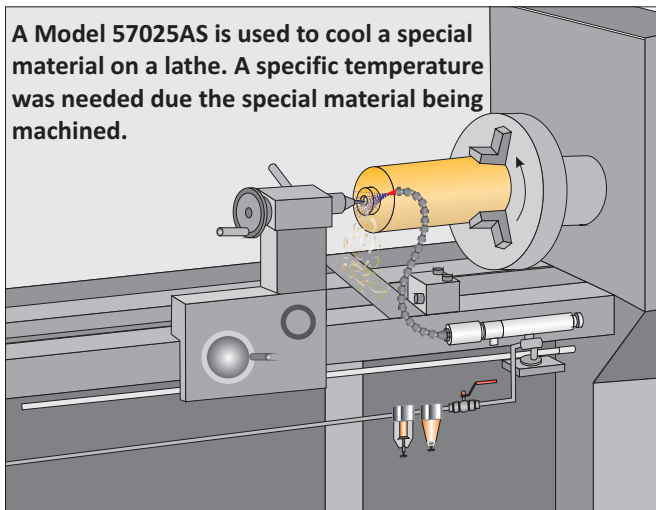

FRIGID-X™ ADJUSTABLE SPOT COOLER

PART NO.	DESCRIPTION
57025AS	Frigid-X™ Adjustable Spot Cooler System c/w cooler, magnetic base, single point hose kit, 25H generator (Installed), 15H generator (loose), 30H generator (loose)
57025AD	Frigid-X™ Adjustable Spot Cooler System c/w cooler, magnetic base, dual point hose kit, 25H generator (installed), 15H generator (loose), 30H generator (loose)
56025A	FRIGID-X™ Adjustable Spot Cooler only
OPTIONS	
90001	Filter with automatic drain, 3/8" NPT, 65 SCFM (1841 SLPM)
90005	Oil Removal Filter, 3/8" NPT, 15-37 SCFM (425 to 1048 SLPM)

